

INSTALLATION AND MAINTENANCE MANUAL



WORLDWIDE ELECTRIC VERTICAL HOLLOW SHAFT MOTORS



WorldWide Electric Corporation
Phone: 1-800-808-2131 Ext. 3
Fax: 1-800-711-1616
Website: www.worldwideelectric.net



TABLE OF CONTENTS

SECTION 1:	General Introduction	
	1.1 Main Specifications	Page 1
	1.2 Operating Conditions	Page 1
	1.3 Motor Construction Features	Page 2
	1.4 Motor Dimensions	Page 3
	1.5 Coupling Dimensions	Page 4
	1.6 Bearing Types / Sizes and Max. Thrust Loads	Page 5
SECTION 2:	Operating Instructions	
	2.1 Inspection Before Operation	Page 6
	2.2 Filling With Oil	Page 6
	2.3 Electrical Connections	Page 7
	2.4 Lead Wire Information	Page 8
	2.5 Pre-Installation Test	Page 9
SECTION 3:	Installation	Page 9
SECTION 4:	Decibel Levels (Sound Levels)	Page 10
SECTION 5:	Warranty Policy	Page 11
SECTION 6:	On-Going Inspection and Maintenance	Page 12
SECTION 7:	Storage	Page 12
SECTION 8:	Shipping Dimensions	Page 13



WorldWide Electric Corporation
Phone: 1-800-808-2131 Ext. 3
Fax: 1-800-711-1616
Website: www.worldwideelectric.net



SECTION 1: General Introduction

1.1 Main Specification:

Vertical hollow shaft motors are three-phase squirrel cage induction motors specially designed for driving deep-well turbine pumps. The motors have been designed according to NEMA standards with the following standard specifications:

Power Supplied 60 Hz, 230/460V or 460V (Suitable for use at 50 Hz, 380V)
Insulation Class: F
Protection Grade: WPI (IP23) With Rodent Screens

1.2 Operating Conditions:

Duty Type: Continuous (SI)
Ambient Temp.: -10°C to 40°C
Max. Altitude: Not more than 3300 F.A.S.L. (1000 M) above seal level
(Contact WorldWide Electric for suitability at higher altitudes)
Suitable For Operation In : Indoor / Outdoor Locations

1.3 Motor Construction Diagram:

The following diagram shows the 280~440 (WPI IP23) Construction Features:

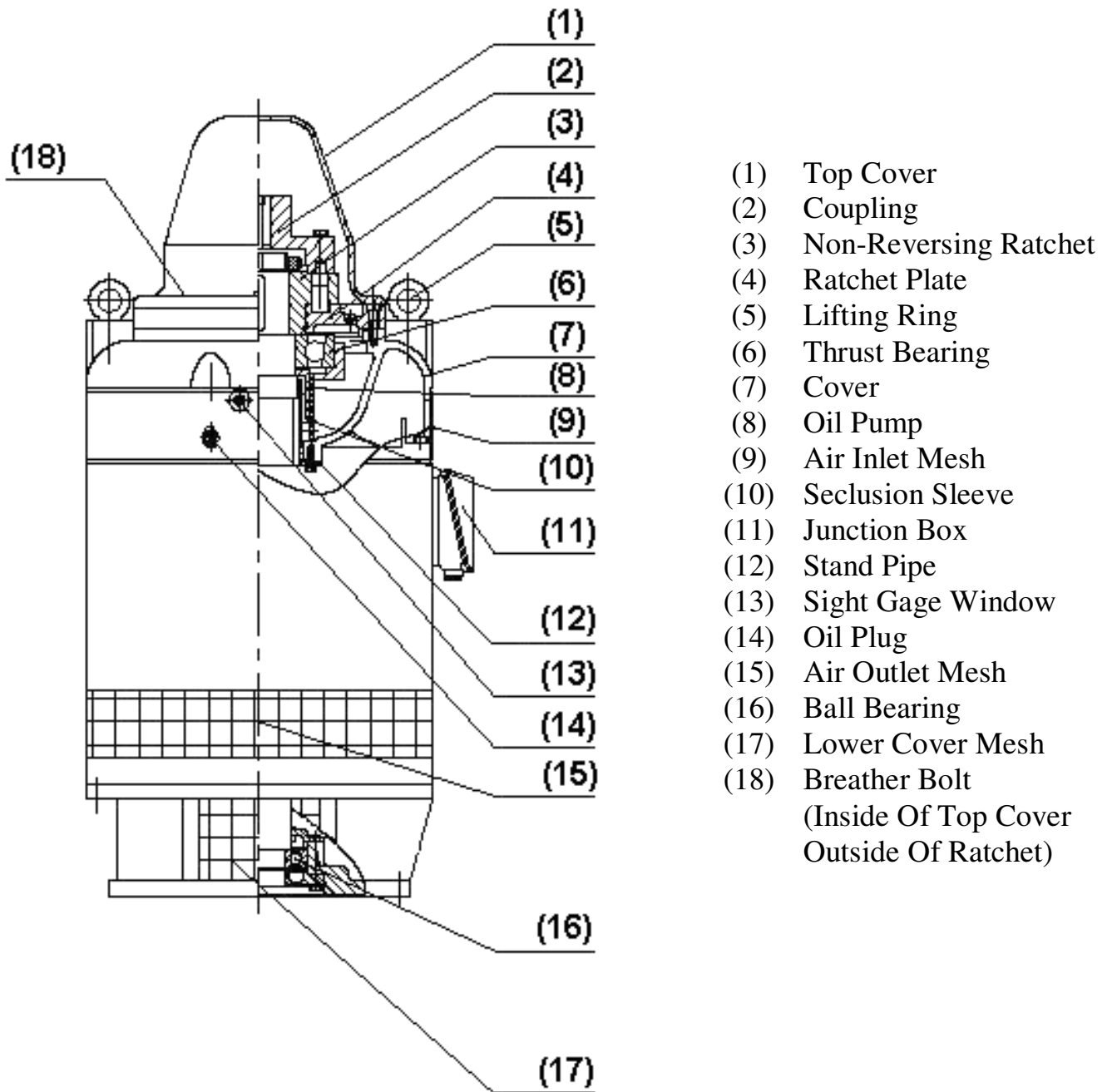

1.4 Motor Dimensions:

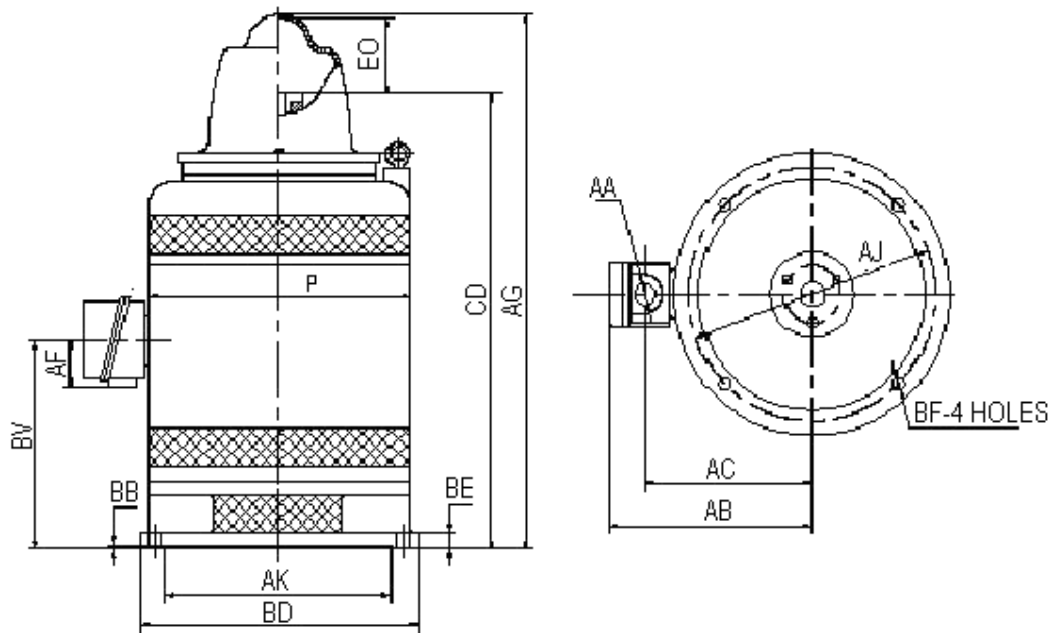

DIMENSIONS - INCHES

FRAME	P	AA	AB	AC	AF	AG	BE	BV	CD	EO	AJ	AK	BB MIN.	BD MAX.	BF
284TPH 286TPH	15.59	3NPT	13.15	10.29	5.02	31.30	0.945	12.44	26.56	4.40	14.75	13.5	0.25	16.5	0.69
284TPA 286TPA	15.59	3NPT	13.15	10.29	5.02	31.30	0.945	12.44	26.56	4.40	9.125	8.25	0.19	12.0	0.44
324TP 326TP	17.32	3NPT	14.57	11.10	5.67	33.06	0.69	11.06	28.22	4.69	14.75	13.5	0.25	16.5	0.69
324TPH 326TPH	17.32	3NPT	14.57	11.10	5.67	33.06	0.69	11.06	28.22	4.69	9.125	8.25	0.19	12.0	0.44
364TP 365TP	21.26	3NPT	19.06	15.59	5.91	36.00	0.69	14.00	31.16	4.69	14.75	13.5	0.25	16.5	0.69
404TP 405TP	21.26	3NPT	19.06	15.59	5.91	42.69	0.75	18.13	36.94	5.50	14.75	13.5	0.25	16.5	0.69
404TPA 405TPA	21.26	3NPT	19.06	15.59	5.91	42.69	0.75	18.13	36.94	5.50	14.75	13.5	0.25	20.0	0.69
444TP 445TP	23.62	3NPT	24.65	19.13	6.24	50.06	0.75	21.19	44.78	5.13	14.75	13.5	0.25	16.5	0.69
444TPA 445TPA	23.62	3NPT	24.65	19.13	6.24	50.06	0.75	21.19	44.78	5.13	14.75	13.5	0.25	20.0	0.69

1.5 Coupling Dimensions:

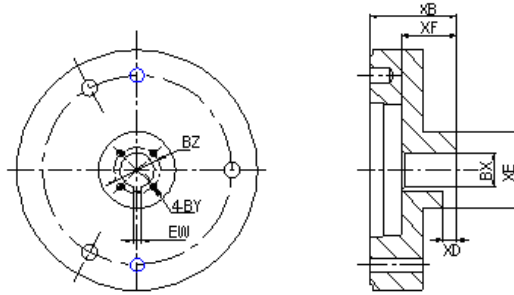

DIMENSIONS - INCHES

FRAME	COUPLING NO.	BX	BY	BZ	XB	XE	XF	SQ KEY (EW)
284/6TP	WCK280-.75	3/4	10-32	1-3/8	2-9/16	2-1/4	1-5/8	3/16
	WCK280-.875	7/8	10-32	1-3/8	2-9/16	2-1/4	1-5/8	3/16
	WCK280-1	1	10-32	1-3/8	2-9/16	2-1/4	1-5/8	1/4
	WCK280-1.0625	1-1/16	10-32	1-3/8	2-9/16	2-1/4	1-5/8	1/4
	WCK280-1.1875	1-3/16	1/4-20	1-3/4	2-9/16	2-1/4	1-5/8	1/4
	WCK280-1.25-.25	1-1/4	1/4-20	1-3/4	2-9/16	2-1/4	1-5/8	1/4
	WCK280-1.25-.375	1-1/4	1/4-20	1-3/4	2-9/16	2-1/4	1-5/8	3/8
324/6TP	WCK320-1	1	1/4-20	1-3/4	2-15/16	2-7/8	1-15/16	1/4
	WCK320-1.1875	1-3/16	1/4-20	1-3/4	2-15/16	2-7/8	1-15/16	1/4
	WCK320-1.25-.375	1-1/4	1/4-20	1-3/4	2-15/16	2-7/8	1-15/16	3/8
	WCK320-1.25-.25	1-1/4	1/4-20	1-3/4	2-15/16	2-7/8	1-15/16	1/4
	WCK320-1.3125	1-5/16	1/4-20	1-3/4	2-15/16	2-7/8	1-15/16	3/8
	WCK320-1.4375	1-7/16	1/4-20	2-1/8	2-15/16	2-7/8	1-15/16	3/8
	WCK320-1.5	1-1/2	1/4-20	2-1/8	2-15/16	2-7/8	1-15/16	3/8
364/5TP	WCK360-1	1	1/4-20	1-3/4	2-15/16	2-7/8	1-15/16	1/4
	WCK360-1.1875	1-3/16	1/4-20	1-3/4	2-15/16	2-7/8	1-15/16	1/4
	WCK360-1.25-.25	1-1/4	1/4-20	1-3/4	2-15/16	2-7/8	1-15/16	1/4
	WCK360-1.25-.375	1-1/4	1/4-20	1-3/4	2-15/16	2-7/8	1-15/16	3/8
	WCK360-1.3125	1-5/16	1/4-20	1-3/4	2-15/16	2-7/8	1-15/16	3/8
	WCK360-1.4375	1-7/16	1/4-20	2-1/8	2-15/16	2-7/8	1-15/16	3/8
	WCK360-1.5	1-1/2	1/4-20	2-1/8	2-15/16	2-7/8	1-15/16	3/8
404/5TP	WCK400-1.1875	1-3/16	1/4-20	2-1/8	3-13/32	3-1/8	2-13/32	1/4
	WCK400-1.25-.25	1-1/4	1/4-20	2-1/8	3-13/32	3-1/8	2-13/32	1/4
	WCK400-1.25-.375	1-1/4	1/4-20	2-1/8	3-13/32	3-1/8	2-13/32	3/8
	WCK400-1.4375	1-7/16	1/4-20	2-1/8	3-13/32	3-1/8	2-13/32	3/8
	WCK400-1.5	1-1/2	1/4-20	2-1/8	3-13/32	3-1/8	2-13/32	3/8
	WCK400-1.5625	1-9/16	1/4-20	2-1/2	3-13/32	3-1/8	2-13/32	3/8
	WCK400-1.6875	1-11/16	1/4-20	2-1/2	3-13/32	3-1/8	2-13/32	3/8
	WCK400-1.8125	1-13/16	1/4-20	2-1/2	3-13/32	3-1/8	2-13/32	3/8
444/5TP	WCK440-1.4375	1-7/16	1/4-20	2-1/2	4	3-11/16	2-7/8	3/8
	WCK440-1.5	1-1/2	1/4-20	2-1/2	4	3-11/16	2-7/8	3/8
	WCK440-1.3125	1-5/16	1/4-20	2-1/2	4	3-11/16	2-7/8	3/8
	WCK440-1.6875	1-11/16	1/4-20	2-1/2	4	3-11/16	2-7/8	3/8
	WCK440-1.75	1-3/4	1/4-20	2-1/2	4	3-11/16	2-7/8	3/8
	WCK440-1.9375	1-15/16	1/4-20	2-1/2	4	3-11/16	2-7/8	1/2
	WCK440-2.1875	2-3/16	1/4-20	3-1/4	4	4	2-7/8	1/2

1.6 Bearing Types Sizes and Max Thrust Loads:

MODEL NUMBER	HP	UPPER THRUST BEARING	MAX. DOWN THRUST (LBS.)	LOWER RADIAL BALL BEARING
VHS25-18-2/4-284TPA VHS25-18-2/4-284TPH	25	7315B	3740	6212Z
VHS30-18-2/4-286TPA VHS30-18-2/4-286TPH	30			
VHS40-18-2/4-324TP VSH40-18-2/4-324TPH	40	7318B	5000	6213Z
VHS50-18-460-326TP VHS50-18-460-326TPH	50			
VHSN60-18-460-364TP	60			
VHS75-18-460-365TP	75	7322B	8800	6317Z
VHS100-18-460-404TP VHS100-18-460-404TPA	100			
VHS125-18-460-405TP VHS125-18-460-405TPA	125			
VHS150-18-460-444TP VHS150-18-460-444TPA	150	7328B	11600	6318Z
VHS200-18-460-445TP VHS200-18-460-445TPA	200			
VHS250-18-460-445TP VHS250-18-460-445TPA	250			

2.1 Inspection Before Operation:

The following steps should be followed carefully before operation:

1. Check nameplate data to make certain that the motor matches requirements.
2. Inspect the general condition of the motor, making certain there are no loose fasteners. Turn the motor in the correct direction of operation to ensure that the motor turns freely and that there was no damage during shipment.
3. Measure the insulation to ground with a megger capable of at least 500 megohms. (Reading should be at least 500 megohms.)
4. Remove top cover and inspect non-reversing ratchet to ensure pins move freely and that it was not damaged during shipment. Lubricate pins if they are sticking at all.

2.2 Filling With Oil:

1. Remove the vent plug (flat head screw), located just outside of the non-reversing ratchet inside of the motor top cover, to prevent a vacuum inside the oil reservoir.
2. Remove the fill plug and fill with ISO VG 32 Turbine Oil to 1/3 up the sight glass.

DO NOT OVERFILL!!

3. Replace the fill plug and the vent plug. Check for oil leaks.
4. For Transportation or storage, oil should be removed and the oil reservoir should be drained and cleaned prior to filling again.

2.3 Electrical Connections:

1. Connect leads according to the following diagrams:

Sketch # 1 is for 460V motors (50 HP and above).

Start connection is provided ONLY if using a part-wind starter.

Wire as per run connection for across-the-line, soft start or for VFD starting.

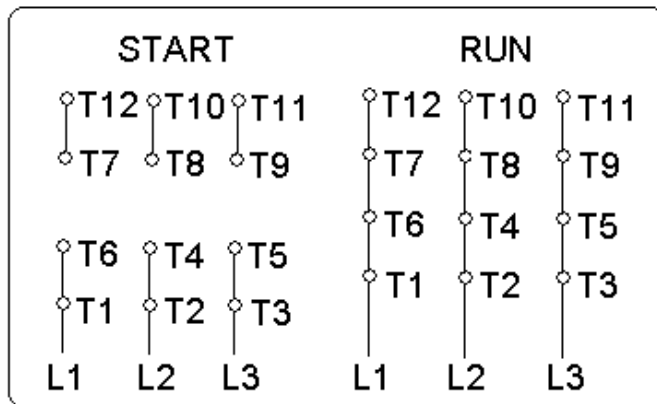

Sketch # 2 is for 230V / 460V motors (25 HP to 40 HP).

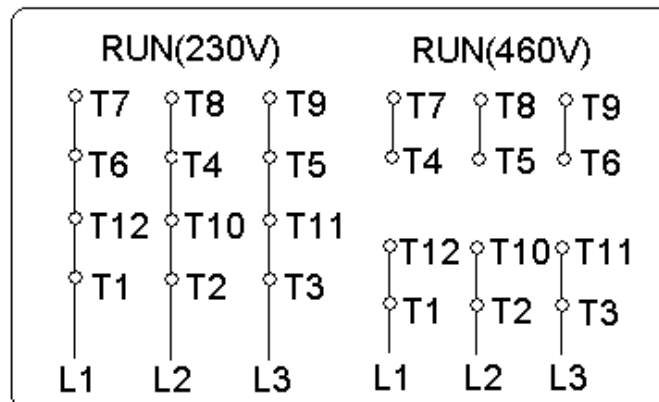

2. The motor must be grounded properly. A grounding terminal is located inside the terminal box.
3. Motors are fitted with 120VAC space heaters. Small gauge leads are in the main terminal box.

2.4 Lead Wire Information:

HP	VOLTAGE	LEAD SIZE	LEAD LENGTH (Inches)
25	230/460	10 AWG	8
30	230/460	8 AWG	8
40	230/460	6 AWG	8
50	460	10 AWG	8
60	460	10 AWG	8
75	460	8 AWG	8
100	460	6 AWG	8
125	460	4 AWG	8
150	460	4 AWG	8
200	460	2 AWG	8
250	460	1/0 AWG	8

2.5 Pre-Installation Test:

1. Check Rotation – When connected correctly, the rotation will be counter-clockwise looking from the top of the motor.
2. Check Voltage – Voltage at the motor leads should be measured to ensure that actual voltage matches the motor's rated voltage with little imbalance (less than 2.5% imbalance between phases).
3. Motor Protection – It is necessary to provide over current or short circuit protection devices in the control panel or motor starter, which should be sized in accordance with the motor's full load current.
4. Test Running – After visually inspecting, filling with oil and the electrical connections are complete, the motor can be test run. If the phase sequence is incorrect, the non-reversing ratchet will stop the motor from running in the wrong direction. Shut off power and switch any two line leads to reverse the motor rotation. Monitor the motor during this test run to make certain there is no noise, vibration or high current to indicate a potential problem.

SECTION 3: Installation

1. Make sure that the motor specifications match that of the pump (i.e. RPM, HP, etc...)
2. During the course of installation, the motor should never be in any position other than vertical. If the motor is tipped more than 10° from vertical, oil will spill from the reservoir.
3. The motor base must be structurally sound to prevent vibration or misalignment. If significant vibration is present following the installation, check the base and alignment for potential problems and contact your installation company.

SECTION 4: Decibel Levels (Sound Levels)

Decibel levels (sound levels) should be measured on motor start-up, after thirty (30) days and after six (6) months. Decibel levels are also an indication as to the vibration levels of an electric motor. A decibel chart has been provided here for your convenience. If the measured motor decibel levels exceed the listed levels by more than ten percent (10%), please consult the motor manufacturer and/or your motor repair center.

MODEL NUMBER	HP	DECIBEL LEVEL
VHS25-18-2/4-284TPA VHS25-18-2/4-284TPH	25	80 dB
VHS30-18-2/4-286TPA VHS30-18-2/4-286TPH	30	
VHS40-18-2/4-324TP VSH40-18-2/4-324TPH	40	
VHS50-18-460-326TP VHS50-18-460-326TPH	50	
VHSN60-18-460-364TP	60	85 dB
VHS75-18-460-365TP	75	
VHS100-18-460-404TP VHS100-18-460-404TPA	100	
VHS125-18-460-405TP VHS125-18-460-405TPA	125	
VHS150-18-460-444TP VHS150-18-460-444TPA	150	90 db
VHS200-18-460-445TP VHS200-18-460-445TPA	200	
VHS250-18-460-445TP VHS250-18-460-445TPA	250	

SECTION 5:

Warranty Policy

1. **Warranty Length** – The warranty length for WorldWide Electric Vertical Hollow Shaft Motors shall be one year from the date of sale (invoice). Discrepancies and allowances on length of warranty or warranty decisions to be made by WorldWide Electric Corporation.
2. **Where To Warranty / By Whom** – WorldWide Electric Motors may be warranted and serviced by any EASA (Electrical Apparatus Service Association) Shop / Member in and outside of the United States. non-EASA Shops may be considered for warranty, but must be approved by WorldWide Electric Corporation in advance.
3. **Procedure** – All Motors must be inspected by a UL Certified EASA or other approved motor shop for determination of cause of failure. If the failure is determined to be warrantable, WorldWide Electric shall either repair or replace the motor. The service station must contact WorldWide Electric Corporation with an estimate of repair. The warranty repair must be approved before the repair may be performed.

SECTION 6:

On-Going Inspection and Maintenance

1. In the course of operation, current and voltage should be measured from time to time to ensure it matches the motor specifications. Whenever abnormal noise occurs during operation, immediate shut-down and inspection is required.
2. The non-reversing ratchet should be checked yearly to ensure no build-up of dirt or debris has occurred that could prevent its proper operation. This should be checked when the oil is being changed.
3. The oil level should be checked through the oil sight gauge periodically to ensure no oil is being lost. The level should be just at or below the center-line of the gauge with a motor at standstill. **THE LEVEL WILL DROP BELOW THE CENTER WHEN THE MOTOR IS IN OPERATION. THIS DOES NOT INDICATE A PROBLEM, IT INDICATES THE OIL PUMP IS WORKING PROPERLY.**

SECTION 7:

Storage

1. When storing the motor(s) for an extended period of time (6 months or more), the following steps should be taken:
 - A. Clean the exterior and interior (inside of top cover) of the motor thoroughly.
 - B. Cover the air inlets and outlets (mesh) of the motor to prevent the entrance of dust.
2. The motor should be stored in a clean and dry environment. The storage area should be free from vibration and be low in humidity. The temperature of the storage area should be between 40°F and 80°F. **If the motor is to be stored outdoor or even installed outdoors without running for a period of one week or more, please energize the space heaters to prevent condensation inside the motor.**

SECTION 8:**Shipping Crate Dimensions / Weights**

HP	FRAME SIZE	1800 RPM		
		NET WEIGHT (Lbs.)	GROSS WEIGHT (Lbs.)	L x W x H (Inches)
25	284TPA	496	595	24.8 x 24.8 x 37.8
	284TPH	515	615	24.8 x 24.8 x 37.8
30	286TPA	507	606	24.8 x 24.8 x 37.8
	286TPH	526	626	24.8 x 24.8 x 37.8
40	324TP	656	773	26.2 x 26.2 x 39.4
	324TPH	639	756	26.2 x 26.2 x 39.4
50	326TP	667	784	26.2 x 26.2 x 39.4
	326TPH	652	769	26.2 x 26.2 x 39.4
60	364TP	960	1084	26.8 x 33.7 x 44.3
75	365TP	996	1119	26.8 x 33.7 x 44.3
100	404TP	1238	1363	26.8 x 33.7 x 50
125	405TP	1278	1403	26.8 x 33.7 x 50
150	444TP	1738	1894	29.9 x 40.9 x 57.9
	444TPA	1762	1919	29.9 x 40.9 x 57.9
200	445TP	1872	2029	29.9 x 40.9 x 57.9
	445TPA	1896	2053	29.9 x 40.9 x 57.9
250	445TPA	2053	2209	58.3 x 50.4 x 58.3